

FLOOR PLAN

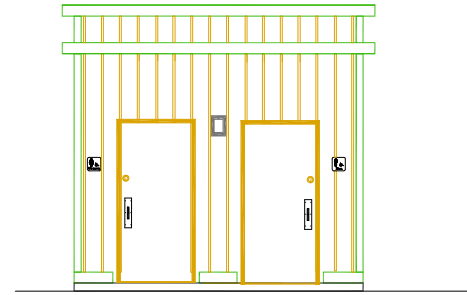

FRONT ELEVATION

NOTE: BUILDING SHOWN WITH 8" O.C.GROOVE PANEL SIDING.

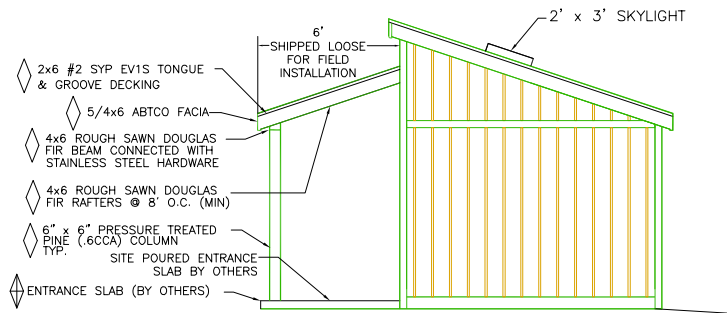

RIGHT ELEV.

◇ ADDITIONAL PIERS REQUIRED  
PIER TYPE P1  
HIGH WIND TYPE P2  
TYPICAL EACH COLUMN

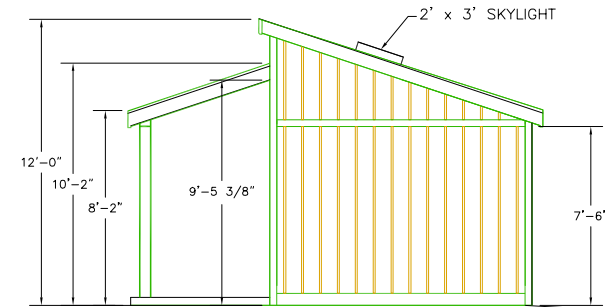

NOTE: BUILDING SHOWN WITH 8" O.C.GROOVE PANEL SIDING.

◇ SYMBOL: SUPPLIED BY MANUFACTURER AND INSTALLED BY OTHERS.

◇ SYMBOL: SUPPLIED AND INSTALLED BY OTHERS.

NOTE: AMMENITIES SUPPLIED MAY BE RELOCATED TO ACCOMMODATE TRAFFIC OR USE PATTERN WITHOUT DEVIATING FROM ADA RULES BUILDING CODES AND MODULAR SHIPPING ABILITY.

MODEL: R22-1214 DR, 2 TOILET,  
2 LAVATORY, RESTROOM BUILDING  
WITH 6' FRONT PORCH ROOF



NOTE:  
LANDINGS, WALKWAYS AND RAMPS ARE TO BE SUPPLIED AND INSTALLED BY OTHERS AS REQUIRED TO MEET LOCAL HANDICAP ACCESSIBILITY REQUIREMENTS.